



AEV SYNAPSE

Broadcast On Air Console



Guarantee

The equipment is warranted for a period of 2 years from the date of invoice (ex-works). The warranty does not cover faults provoked by carelessness, natural causes and parts subject to wear. In addition, the cost of shipment is not covered. The warranty will be voided if the equipment is mishandled.

Technical Support

If you require technical support, contact AEV SERVICE giving a clear and concise account of your specific problem. Quote the serial number of your equipment by referring to the AEV nameplate attached to the equipment itself as this is the most important piece of information to be provided. Telephone: +39 051892963 Fax: +39 051893605

Factory Service and Repairs

If problems arise while the equipment is being installed, consult this manual and check that the installation is being carried out properly. If the problems still cannot be solved, call the AEV SERVICE Department for further information. If the problem is a minor one a telephone call will probably suffice. If, on the other hand, the equipment is to be shipped to AEV for service or repairs, the AEV SERVICE Dept. will accept it only if the RMA return authorisation number has been provided. This number must be included in the shipping documents. We also recommend providing a detailed description of the fault which has occurred, the type of service needed and (if required) the name of the employee at the AEV SERVICE Dept. you have spoken to. No repairs will be made if the cost of shipment is charged to AEV. In this case, we will not accept the delivery.

Shipping Instruction

When shipping the equipment to AEV, use the original package in order to be certain that it will be fully protected during handling. If you need the original package, call us for a new one. If you ship the equipment in a different packing container, take care to provide a double package by interposing padding material between the two containers in order to fully protect the equipment during shipment. The package should be marked "FRAGILE" in red.

IMPORTANT: Carefully read this paragraph as it contains important instructions concerning operator safety and directions regarding the installation, operation and maintenance of the equipment.

Failure to observe the safety instructions and information given in this manual **constitutes an infringement of the safety rules and design specifications provided for this piece of equipment.**

Futurcom srl declines all responsibility if any one of the safety rules given herein is not observed.

Futurcom srl declines all responsibility if the end-user resells the product.

The equipment is to be used by people capable of operating it in a trouble-free manner and **it is assumed that they are aware of the following safety rules.**

- Keep this manual with the utmost care and close at hand so that it can be consulted whenever needed
- After unpacking the equipment, check it for condition.
- Avoid banging the equipment.
- The packing material (plastic bags, polystyrene, nails, etc.) must never be left within the reach of the children, as **these items are potential sources of danger.**
- Do not use the equipment in places where the temperature is not within the recommended range, as specified by the manufacturer.
- Before connecting the equipment, make sure the nameplate specifications correspond to the mains electricity supply (the nameplate is located on the equipment enclosure).
- Do not remove the sticker from the equipment as it contains important specifications and the relevant serial number.

- To join the equipment to the mains supply, use the power cord purchased with the equipment.
- The equipment must be used only for the purpose it was designed for.
- Abuse or misuse of the equipment is **extremely dangerous** for people, pets and property. The manufacturer declines all responsibility for damage and injury resulting from **improper use** and **mishandling**.
- Certain basic safety rules must be observed when using electrical equipment, in particular: - Never touch the equipment with wet and/or damp hands or other parts of the body.
 - Keep the equipment away from drops of water or sprinkling systems.
 - Never use the equipment near high heat sources or explosive material.
 - Do not introduce any extraneous matter into the equipment.
 - Do not allow children or untrained people to use the equipment.
- Before cleaning or servicing the equipment outside, disconnect it from the supply and wait at least 2 seconds before working on it, as recommended by current safety regulations.
- In the event of faults and/or improper operation, turn off the equipment, shut off the electrical power and call your dealer.
- Do not attempt to make repairs and/or adjustments when covers/guards or circuit boards are to be removed.
- Blown fuses inside the power supply indicate that there may be a fault in the power supply itself. The fuses must be replaced by qualified and authorised persons. It is advisable to call your nearest dealer.
- Call your dealer for any repairs and be certain original spare parts are used.

Failure to observe this rule may adversely affect the safety level of your equipment.

- The equipment is to be connected to the mains supply and provided with adequate and efficient earth conductors.
- The electrical wiring must be done in compliance with current electrical codes CEI 64-8 "Electrical specification for domestic buildings".
- When installing, leave a clearance of at least 1 cm around the equipment to allow air to pass freely.

NOTE. This piece of equipment has been manufactured to the highest standards of workmanship. It must be used properly and serviced as recommended to ensure long-term dependable operation.

The installation must be done in order to be able to guarantee an easy access to the cable of feeding.

The device of dissection of the equipment is the cable of feeding, so it must be unconnected from the equipment every time it is necessary to do any type of maintenance.

Contents

Guarantee.....	1
Factory Service and Repairs	1
Shipping Instruction	1
Contentents.....	4
Features.....	5
Input functions and channels	5
Outputs	5
External controls	5
Monitoring	5
General functions	5
Input Configuration.....	5
Micro - Line Module	6
Line - Line Module	7
Digital input Module.....	8
Telephone module	9
Tone Control module	10
Tone Control & Digital Outputs module	11
Master module	12
General functions	13
Insert	13
Phantom	13
Start	13
Cue	13
Stop	13
Slider	13
Tally	13
Timer restart.....	13
Fader Auto Start/Stop.....	13
No Echo on CMD Remote.....	13
OUT/AUX Configuration	13
Direct Controls	14
Control Room Section	14
Control Studio Section	14
Headphones Section	14
Cue Speaker Section	14
Using the Talk Back Mode.....	14
Talk Back from Control Room (Master control)	14
Talk Back from Control Studio (DJ)	14
Mic - Line Input & Insert Pin-out / Setup	15
Mic Input connection	16
Line - Line Input Pin-out	19
Line Input connection	20
Digital Input Pin-out	21
Telephone Pin-out / Setup	22
GPI - GPO Pin-out	23
Master Setup	24
Master Pin-out	25
Master Output connection (PGM - UTL -C.STUDIO - C.ROOM).....	26
Master Input connection (EXT 1 - EXT 2)	27
Master Digital Pin-out	28
Technical Specification	29
General Specifications.....	31

Features

- 16-channels audio inputs:** Transformer balanced Micro inputs- electronically balanced
Line inputs- Phone Inputs, Digital Inputs AES/EBU, Tone Control
- Faders:** Faders (100 mm) with A/B input selector
- Tone Control:** The 3 bands Tone Control Module is one for all the inputs.

Input functions and channels

(All settings are independent for each input, via dip-switches (A/B).

- Input source selection
- Level control
- Phantom Power supply (only for Micro inputs)
- Insert (only for Micro inputs)
- Input mute enabling in the event of failure (only for digital inputs)
- Bus assignment
- Timer Restart
- Tally 1
- Logic control for the START-STOP functions
- Intercom

Outputs

- PGM:** digital AES/EBU + Analog stereo
- UTL:** digital AES/EBU + Analog Stereo
- CONTROL ROOM:** Analog Stereo
- CONTROL STUDIO:** Analog Stereo
- HEADPHONES:** Analog Stereo
- Digital PGM and UTL** with sample rate selection (Opt.)

External controls

- Remote Fader with logic controls, (TB, On-Off, Cough)
- GPI Opto-isolated logic inputs
- GPO Opto-isolated logic outputs
- ON AIR Tally
- TalkBack Output

Monitoring

- Level control for headphones, Control Room, Control Studio
- 2 External inputs for Monitor
- Headphones with integrated amplifier
- Cue loudspeaker with built-in amplifier
- VU-Meter on 4 instruments

General Functions

- Integrated Talk-Back microphone
- Watch restart

Input Configuration

Four different types of input are provided: microphone, analog line, digital line (AES/EBU) and telephone input.

Micro - Line Module



- 1 - 15-pin connector (microphone input), the pin-out out-pin is provided in the technical section.
 - 2 - 15-pin connector (line input), Connettore 15 poli the pin-out out-pin is provided in the technical section.
 - 3 - Trimmer for adjusting the input levels from 0 to + 30 dB for very low-tone microphones.
 - 4 - Button for the fine adjustment of the input levels (max. attenuation - 12dB). This is a shared button but its function is customised for two inputs.
 - 5 - Button for the fine adjustment of the input levels (max. amplification: +12dB). This is a shared button but its function is customised for two inputs.
 - 6 - Dip-switch for microphone channel setup (Timer, Insert, Talk- Back, Mute, Tally, Auto-Start, Echo and Remote).
 - 7 - Dip-switch for Line channel setup (Timer, Talk Back, Mute, Tally, Auto-Start, Echo and Remote).
 - 8 - Button for selecting the input source (Micro or Line).
 - 9 - Light indicator, Micro input On.
 - 10 - Light indicator, Line input On.
 - 11 - Button for assigning the channel to the PGM bus.
 - 12 - Button for assigning the channel to the UTL bus.
 - 13 - Button for enabling CUE pre-listening.
 - 14 - Fader.
 - 15 - START button, the channel signal is sent to the UTL and/or PGM buses enabled by buttons 11 and 12, the CUE is disabled and a pulse is sent to the optional remote control (if installed).
 - 16 STOP button, the channel signal is no longer sent to the PGM and/or UTL buses selected. A pulse is sent to the optional remote control (if installed).
- If capacitor microphones are used, the Phantom power supply will be wired to connector 1, see technical section.

Line - Line Module



- 1 - 15-pin input connector, line A input, the pin-out is available in the technical section.
- 2 - 15-pin input connector, line B input, the pin-out is available in the technical section.
- 3 - Button for the fine adjustment of input levels (max. attenuation: - 12 dB). This is a shared button but its function is customised for two inputs.
- 4 - Button for the fine adjustment of the input levels (max. amplification: +12dB). This is a shared button but its function is customised for two inputs.
- 5 - Setup of line A channel.
- 6 - Setup of line B channel.
- 7 - Button for selecting the input source (Line A or Line B).
- 8 - Indicator light, Line A input On.
- 9 - Indicator light, Line B input On.
- 10 - Button for assigning the channel to the PGM bus.
- 11 - Button for assigning the channel to the UTL bus.
- 12 - Button for enabling CUE pre-listening.
- 13 - Fader.
- 14 - START button: the channel signal is sent to the PGM and/or UTL buses selected by buttons 11 and 12. CUE is inactivated and a pulse is sent to the optional remote control (if installed).
- 15 - STOP button: the channel signal is sent to the PGM and/or UTL buses selected and a pulse is sent to the optional remote control (if installed).

Double Digital input Module



- 1 - DB9 / Optical input connectors, line A input, the pin-out is available in the technical section.
- 2 - DB9 / Optical input connectors, line B input, the pin-out is available in the technical section.
- 3 - Button for the fine adjustment of input levels (max. attenuation - 6 dB). This is a shared button but its function is customised for two inputs.
- 4 - Button for the fine adjustment of the input levels (max 0dB). This is a shared button but its function is customised for two inputs.
- 5 - Setup of line A channel.
- 6 - Setup of line B channel.
- 7 - Button for selecting the input source (Line A or Line B).
- 8 - Indicator light, Line A input On.
- 9 - Indicator light, Line B input On.
- 10 - Button for assigning the channel to the PGM bus.
- 11 - Button for assigning the channel to the UTL bus.
- 12 - Button for enabling CUE pre-listening.
- 13 - Fader.
- 14 - START button: the channel signal is sent to the PGM and/or UTL buses selected by buttons 11 and 12. CUE is inactivated and a pulse is sent to the optional remote control (if installed).
- 15 - STOP button: the channel signal is sent to the PGM and/or UTL buses selected and a pulse is sent to the optional remote control (if installed).

Telephone module

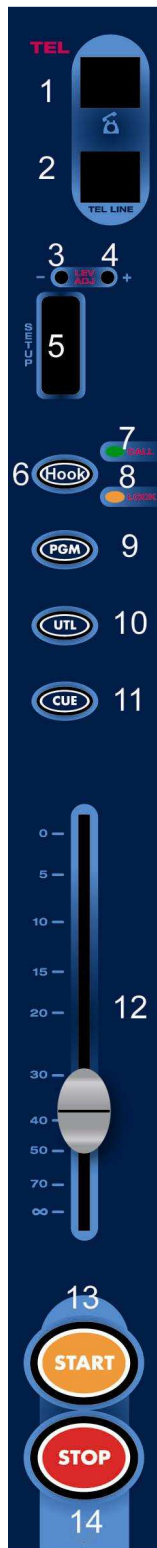

- 1 - Connector RJ45 for telephone service
- 2 - Connector RJ45 for telephone line.
- 3 - Button for the fine adjustment of the input levels (max. attenuation: - 12dB).
- 4 - Button for the fine adjustment of the input levels (max. amplification: +12dB).
- 5 - Dip-switch for telephone channel set-up (Timer, Mute, Tally, Auto- Start, Echo, Line and Remote gain).
- 6 - HOOK button for telephone hook-up.
- 7 - Indicator light for incoming telephone calls.
- 8 - Indicator light for line hook-up.
- 9 - Button for assigning the channel to the PGM bus.
- 10 - Button for assigning the channel to the UTL bus.
- 11 - Button for enabling CUE pre-listening.
- 12 - Fader.
- 13 - START button: the channel signal is sent to the PGM and/or UTL buses selected by buttons 11 and 12, CUE is inactivated and a pulse is sent to the optional remote control (if installed).
- 14 - STOP button: the channel signal is not sent to the PGM and/or UTL buses selected and a pulse is sent to the optional remote control (if installed).

Operation

When the CALL Led is flashing, this means that a telephone call is being received.

Press the HOOK button to hook up the telephone line; the respective Led lights up. To disable the telephone line, press the HOOK button again.

The "Meeting" function to connect two telephone users is enabled only if the respective telephone modules are in PGM or UTL mode.

The telephone modules in "St.by" mode enable the audio functions on the PGM master module.

The director can speak privately with the telephone users on the respective telephone modules by pressing the CUE button and Tb button so that his/her microphone can be activated.

The speaker can talk privately to the telephone users on the respective modules if the DJ has pressed the CUE button on the respective module, the CUE bus has been assigned to the Control Studio output, the channel has been switched over to STOP mode and the TB button is pressed (Mike A connector); this button is connected to the microphone module

Tone Control Module



The Tone Control Module must be inserted on the left of the Master Module.

The Tone Control Module has three different settings: 1 Treble, 2 Mid, 3 Bass.

These commands use encoders that work by pressing and rotating them.

In order to set the equalization of a channel, it is necessary to select the A or B input of the channel and press the Cue button. The leds on the Tone Control Module will show the current equalization (1 led for each band; the default is 0, 0, 0). The "editing" function is activate by pressing the encoder (the leds, one for each encoder, start blinking); now it is possible to modify the equalization. In order to save the equalization press one of the encoders.

In case a Cue button is pressed without intention while the editing process is on, the equalization is saved and it is showed the one of the channel related at the Cue button pressed.

When the settings for each cannel (A and B inputs) have been done and none of the Cue button is pressed the Tone Control Module leds are switched off.

Tone Control and Digital Outs Module



1 - DB9 / Optical connectors, PGM AES3 digital outputs.

2 - DB9 / Optical connectors, UTL AES3 digital outputs.

3 - DIP-Switch used for PGM output Sample-Rate setting.

4 - DIP-Switch used for UTL output Sample-Rate setting.

The Tone Control Module has three different settings: 5 Treble, 6 Mid, 7 Bass.

These commands use encoders that work by pressing and rotating them.

In order to set the equalization of a channel, it is necessary to select the A or B input of the channel and press the Cue button. The leds on the Tone Control Module will show the current equalization (1 led for each band; the default is 0, 0, 0). The "editing" function is activate by pressing the encoder (the leds, one for each encoder, start blinking); now it is possible to modify the equalization. In order to save the equalization press one of the encoders.

In case a Cue button is pressed without intention while the editing process is on, the equalization is saved and it is showed the one of the channel related at the Cue button pressed.

When the settings for each cannel (A and B inputs) have been done and none of the Cue button is pressed the Tone Control Module leds are switched off.

Master module



- 1** - 9 pin connector, Control Studio output.
- 2** - 9 pin connector, UTL master output.
- 3** - 9 pin connector, External input, EXT 2 IN.
- 4** - 9 pin connector, Muted Control Studio output.
- 5** - 9 pin connector, PGM Master output.
- 6** - 9 pin connector, External input, EXT 1 IN.
- 7** - 9 pin connector, Control Room output.
- 8** - 6.3-mm jack connector to the OAL (On Air Light).
- 9** - Service connector to join the Vu-meter and a restart timer control (if any).

- 10** - Button for the fine adjustment of the EXT input levels (max. attenuation: -15 dB). This button is shared but its function is customised for two inputs. To make the adjustments, enable the desired input by using the VU selector.
- 11** - Button for the fine adjustment of the EXT input levels (max amplification: +15dB). This button is shared but its function is customised for two inputs. To make the adjustments, enable the desired input by using the VU selector.
- 12** - Dip-switch for setting up the following functions: Fader range, Control Room DIM, CUE INT, PGM master level and UTL master level.
- 13** - Integrated loudspeaker
- 14** - Button for enabling the EXT 1 input for VU-Meters Switched.
- 15** - Button for enabling the EXT 2 input for VU-Meters Switched.
- 16** - Button for enabling the PGM Master output for VUMeters Switched.
- 17** - Button for enabling the UTL Master output for VUMeters Switched
- 18** - Button for enabling the EXT1 input for the Control Room.
- 19** - Button for enabling the EXT2 input for the Control Room.
- 20** - Button for enabling the PGM Master output for the Control Room.
- 21** - Button for enabling the UTL Master output for the Control Room.
- 22** - Button for enabling the EXT1 input for the Control Studio.
- 23** - Button for enabling the EXT2 input for the Control Studio.
- 24** - Button for enabling the PGM Master output for the Control Studio.
- 25** - Button for enabling the UTL Master output for the Control Studio.
- 26** - Button for enabling the CUE output for the Control Studio.
- 27** - Service microphone to be used when the DJ and the speaker are to talk on the telephone without being overheard.

- 28** - Button to enable the "Talk Back" control. Press the button to activate the service microphone so that it will be possible to talk to the Speaker. The button lights up when the Speaker is calling the DJ.
- 29** - Potentiometer to adjust the Control Studio output level.
- 30** - Potentiometer to adjust the integrated loudspeaker level (13).
- 31** - Potentiometer to adjust Control Room output level.
- 32** - Potentiometer to adjust the headphone output level

General functions

Insert

This function is used to route the microphone signals to the INSERT output section and not to the analog bus. The signal can therefore be used as an input in an external audio processor. Once the signal has been processed, it can be sent back to the INSERT input and passed to the analog bus. This function is enabled through connector 1 (pin 4 and 5, if the function is not used, provide a jumper between these pins).

Phantom

This function is used to power up the capacitor microphones and can be enabled for all microphone inputs. The function is activated through connector 1 (provide a jumper between pins 6 and 7).

Start

When START button is pressed it lights up and enables the channel. A pulse is sent to the remote control (if the option is provided). In addition, the STOP and CUE lighted buttons go off if they were previously enabled.

Cue

The CUE function (pre-listening) can be enabled, according to the settings of the dip switches, in *Interlock* mode, i.e. when a CUE button of any module has been pressed, the one previously selected will be disabled or, in *Standard* mode, the CUE function can be activated for one channel at the same time as the other channels

Stop

When the STOP button is pressed it lights up, the channel is inactivated and a pulse is sent to the remote control (if the option is provided). In addition, the START lighted button goes out.

Slider

The Slider controls the channel audio level and creates a Start condition (by increasing the audio level) and a Stop condition (by decreasing the audio level) provided that the specific functions have been enabled by using the relevant dip-switches. The description given above for the remote controls also apply.

Tally

When this function is enabled for a channel by using the dip-switches (DIP 7 ON), a stable contact is activated. The channel is in Start mode and is assigned to the PGM bus.

Timer restart

When this function is enabled for a channel by using the dip-switches (DIP 1 ON), press the channel START button to send a restart command to the external TIMER (master module, connector 9, pins 4 and 12), 250-ms pulse.

Fader Auto Start / Stop

When this function is enabled for a channel by using the dip-switches (DIP 8 ON), move the SLIDER up so that the channel can be automatically set for the START mode; move the slider down to switch the channel over to Stop mode.

Setup threshold Auto START/STOP

Enable the Auto Start / Stop through the dip 8

- Module status in the Start
- Place the cursor on the slider on the threshold chosen for the activation of Auto Stop
- Press and hold the Stop button for at least 6 sec. Until the LED selection A / B flashes, so the data is stored
- Place the cursor on the slider on the threshold chosen for the activation of Auto Start
- Press and hold the Start button for at least 6 sec. Until the LED selection A / B flashes, so the data is stored
- Place the cursor on the slider to the minimum value, then the maximum and finally back to a minimum

No echo on cmd remote

When this function is enabled for a channel by using the dip-switches (DIP 9 ON), a start signal will be received from the outside, the channel switches over to START mode and no other commands are given. This function serves when pulsed start/stop devices that use a single wire are provided. The Start Echo would disable the same source. On the other hand, in OFF mode, the signal would be sent back to the output section.

OUT/AUX Configuration

The mixer can be provided with the following inputs and outputs:

- two external analog inputs EXT 1 and 2
- one digital PGM AES/EBU + PGM analog output
- one digital UTL AES/EBU + UTL analog output

Direct controls

Control Room Section

The Control Room audio output level may be adjusted via the C. Room potentiometer located on the panel.

EXT1

The following procedure can be performed by pressing the EXT1 button: input signal EXT1 is sent to the Control Room output section and the function previously enabled with the Control Room bar is inactivated.

EXT2

Press button EXT2 to perform the following procedure: the EXT2 input signal is sent to the Control Room output section and the function previously enabled with the Control Room bar is inactivated.

PGM

Press the PGM button to perform the following procedure: the PGM input signal is sent to the Control Room output section and the function previously activated with the Control Room bar is disabled.

UTL

Press the UTL button to perform the following procedure: the UTL input signal is sent to the Control Room output section and the function previously activated with the Control Room bar is disabled.

Cue

Press the CUE button for the following procedures: the CUE bus signal is sent to the Control Studio output section and the Control Studio bus function previously activated is disabled.

TB

Press the TB button (talk back) to send the service microphone signal to the buses selected from the "AUX In/Out Setup" menu.

WARNING The microphone signal replaces the signal that has been assigned to the preset outputs. Release the TB button to restore the previous operating state.

PRIVATE calls to telephone hybrids (if any) can be only made by using the TB microphone signal with the "TELCO" channel in STOP mode and CUE enabled.

Headphones Section

The headphone audio output level is adjusted by using the "Headphone" potentiometer on the panel. A signal assigned to the Control Room is normally sent to the headphone output. When one of the CUE buttons of any channel is enabled, the CUE signal will replace the Control Room signal. There may be exceptions depending on whether the DIM function is enabled or not.

CUE Speaker Section

Speaker Volume

Used to adjust the Speaker Monitor volume with the SYNAPSE mixer. The signal to be sent to the loudspeaker is chosen from the "CUE configuration" menu.

How to use the Talk-Back mode

Talk-Back from Control Room (Director)

The TB from the Control Room (director) can be sent to a Control Studio (DJ), TELEPHONE, UTL and PGM.

If the TB signal is received from the Control Room, the internal microphone signal will be passed to the Control Studio (Speaker) and replaces the audio system previously enabled.

The same TB signal from the Control Room activates the Mute function in the Control Room output section in order to avoid Larsen effects.

If TELCO 1 is in STOP mode and CUE ON, the TB signal is sent to TELCO 1 and not to the Control Studio.

This prevents the DJ from being disturbed by private telephone calls and vice-versa.

Talk Back from Control Studio (DJ)

The TB signal from the Control Studio (DJ) is sent to the Control Room (Director) and to the telephone bus if the telephone module is in STOP mode (private telephone calls being made).

Mic -Line Input & Insert Pin-out Setup

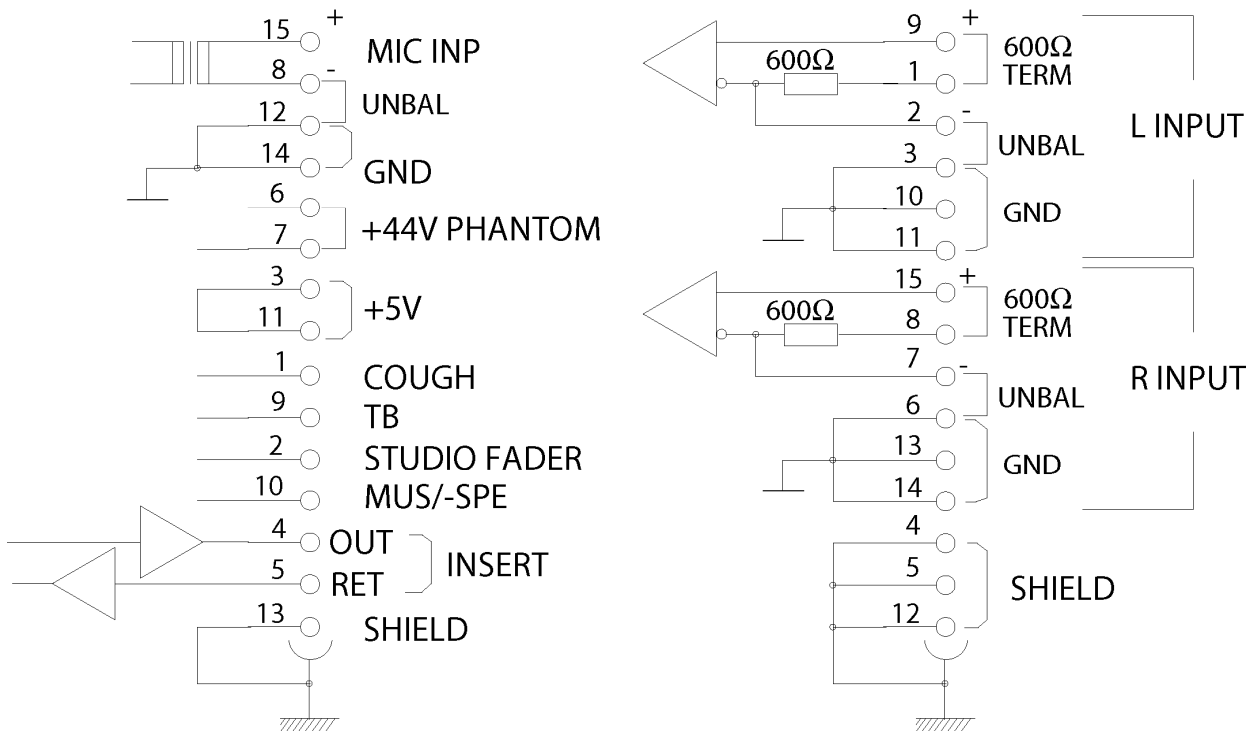
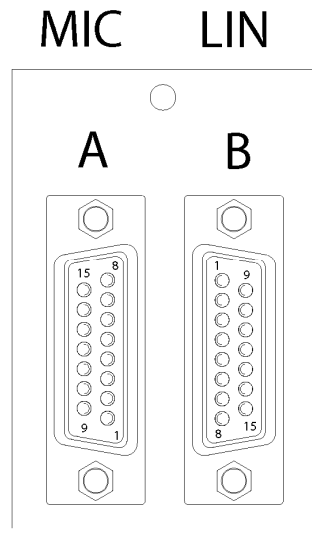

Mic - Line Input connection

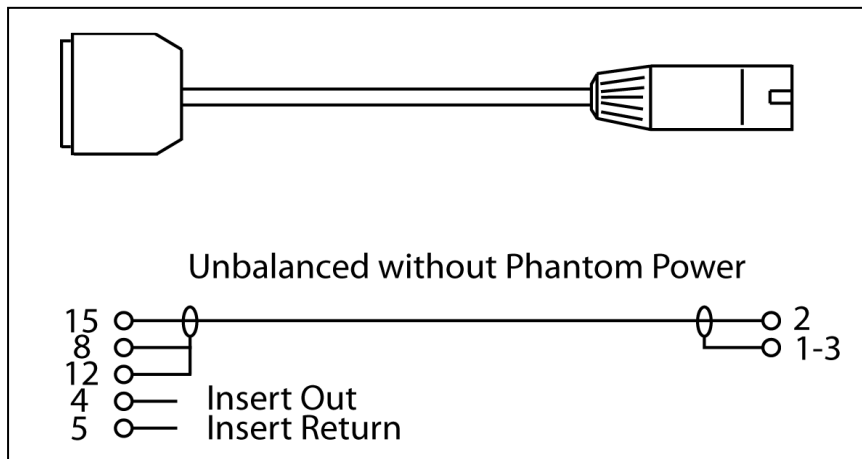
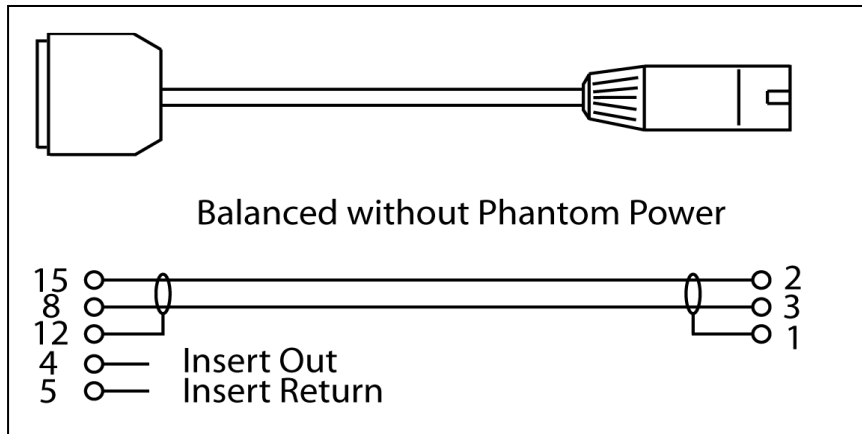
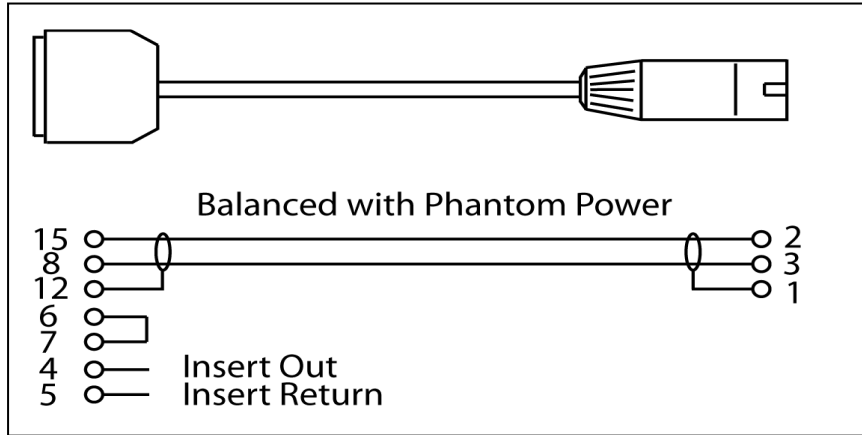

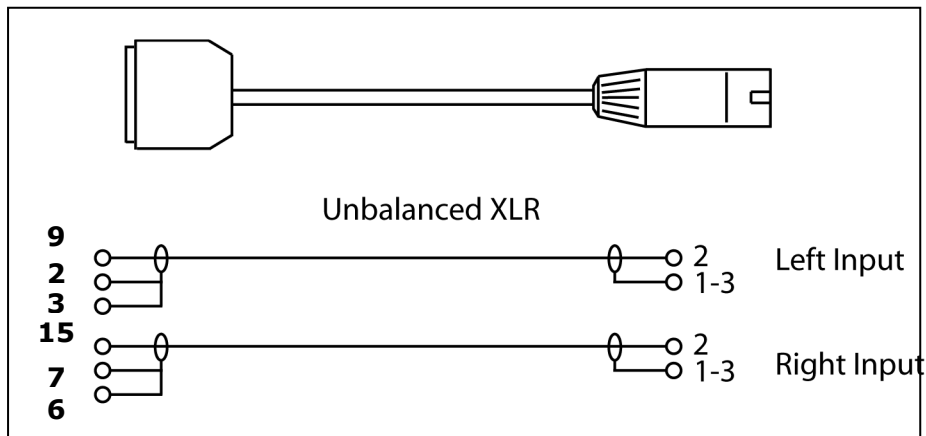
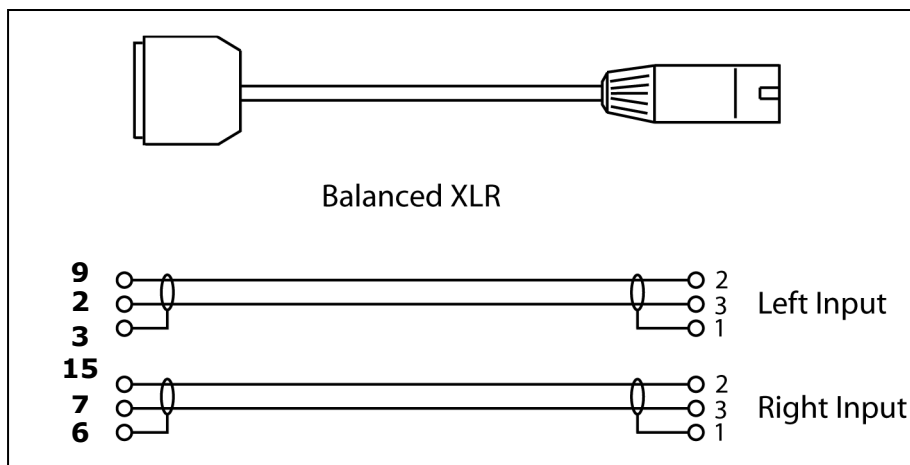
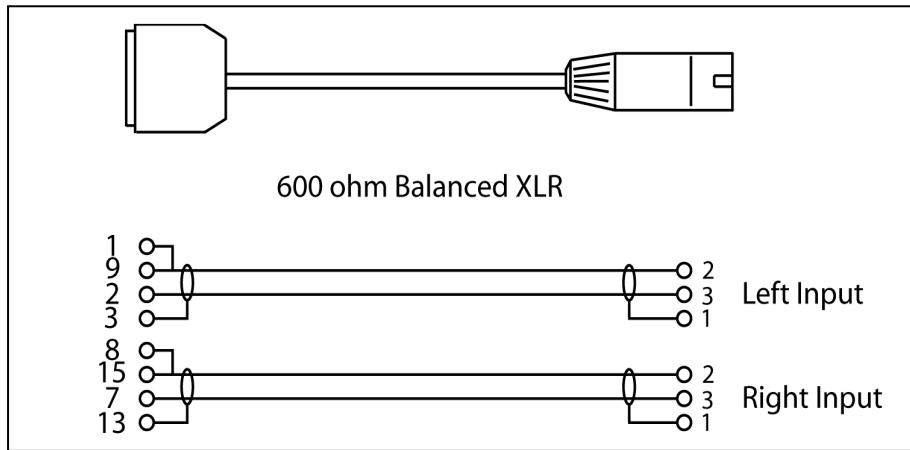

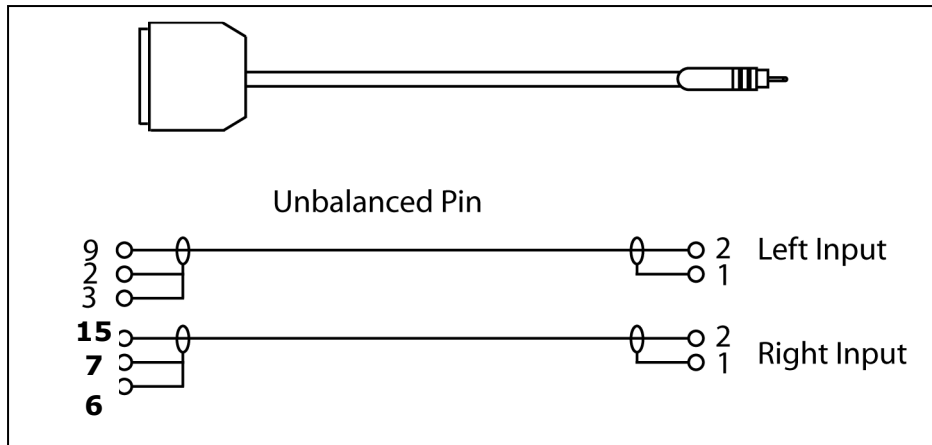

Mic - Line DIP SWITCH FUNCTION NOTES

A	B	OFF ON	
/	1		Reset Timer When the channel switches over to START mode, a pulse is emitted (through the VU-Meter connector) to restart the external timer
1	/		Insert The INSERT telephone plug function is enabled (only through A)
2	2		DJ TEL When the channel is in STOP mode, the audio signal is sent to TEL BUS (private telephone calls)
3	3		TB-Studio/Room When the channel is in STOP mode, press the TB button to send the signal to the output of the Control Room, Headphones and Speaker and the Control Studio Mute is disabled
4	4		Speaker Mute When the channel changes over to START mode, the Speaker output will be disabled
5	5		CR Mute When the channel changes over to START, the Control Room output will be disabled
6	6		ST Mute When the channel changes over to START mode, the Control Studio output is disabled
7	7		ON AIR Tally When the channel changes over to START mode, with the PGM activated, the ON AIR control contact closes
8	8		SLIDER S/S Move the slider up to START; move it down to STOP
9	9		REM ECHO The same command received , START or STOP, is sent to the device connected
10	10		S/S STAB S/S IMPULS The logic outputs are stable in the OFF position; pulsed in the ON position (~ 1 sec), if the option is provided

Line - Line Input Pin-out

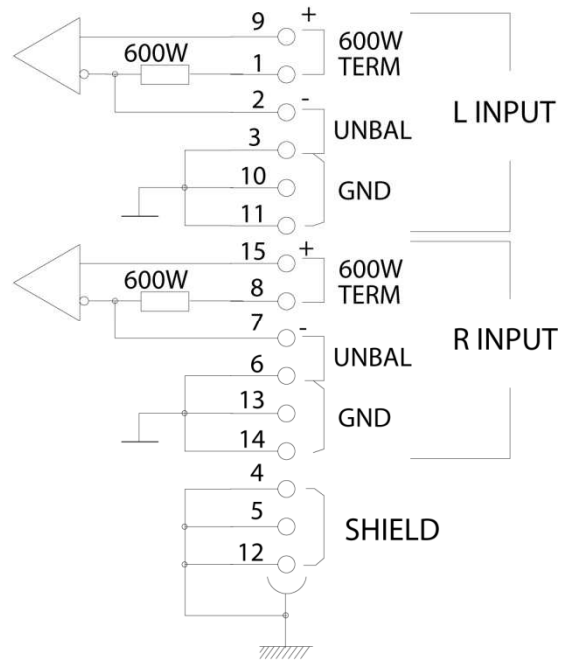
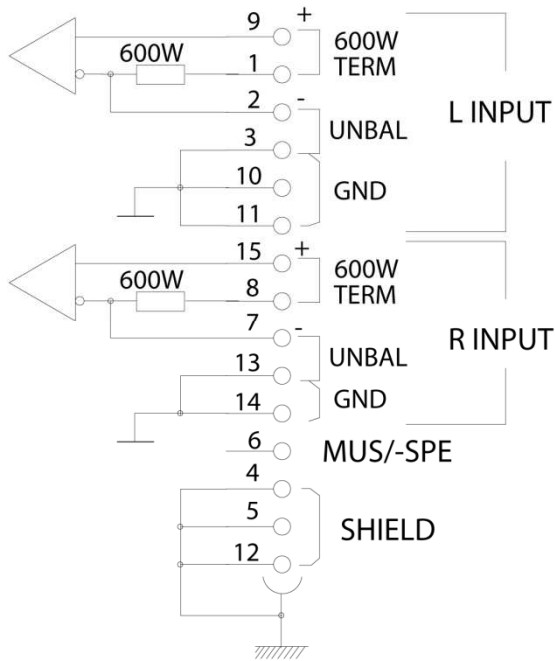
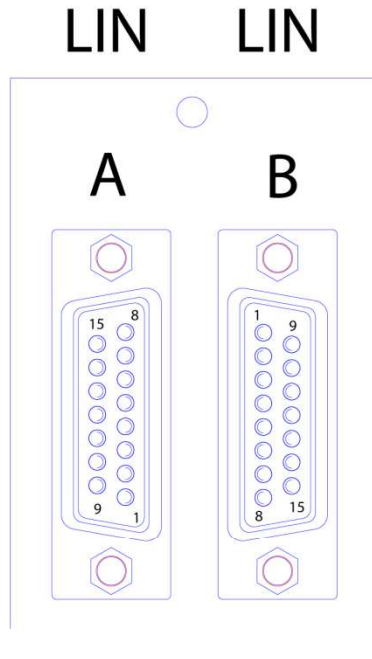

CONNESSIONI INGRESSO MODULO LINEA/LINEA

Line - Line Input connection

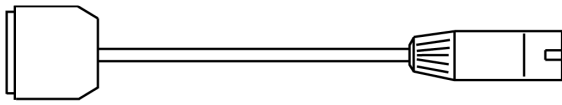

600 ohm Balanced XLR

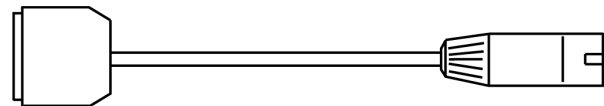
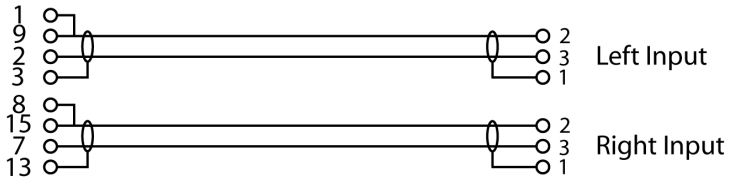

Balanced XLR

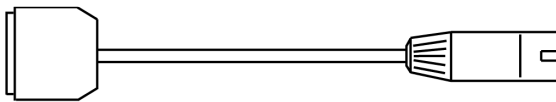
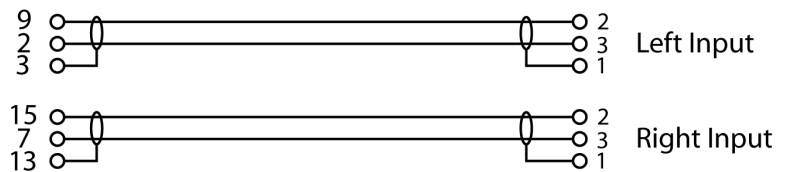

Unbalanced XLR

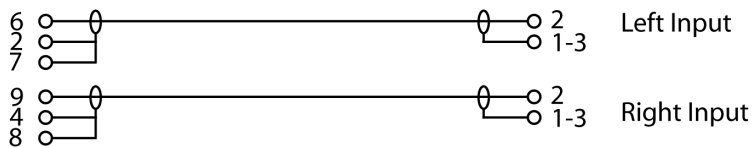

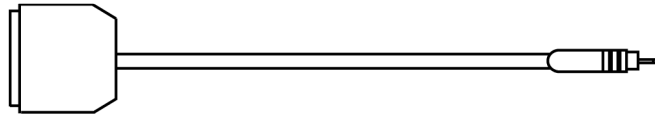

Unbalanced Pin

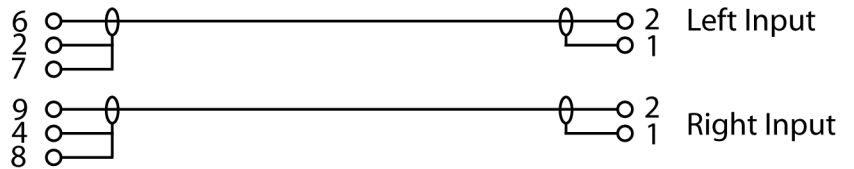

Line - Line Input DIP SWITCH FUNCTION NOTES

A	B	OFF ON
/	1	Reset Timer When the channel switches over to START mode, a pulse is emitted (through the VU-Meter connector) to restart the external timer
1	/	Insert The INSERT telephone plug function is enabled (only through A)
2	2	DJ TEL When the channel is in STOP mode, the audio signal is sent to TEL BUS (private telephone calls)
3	3	TB-Studio/Room When the channel is in STOP mode, press the TB button to send the signal to the output of the Control Room, Headphones and Speaker and the Control Studio Mute is disabled
4	4	Speaker Mute When the channel changes over to START mode, the Speaker output will be disabled
5	5	CR Mute When the channel changes over to START, the Control Room output will be disabled
6	6	ST Mute When the channel changes over to START mode, the Control Studio output is disabled
7	7	ON AIR Tally When the channel changes over to START mode, with the PGM activated, the ON AIR control contact closes
8	8	SLIDER S/S Move the slider up to START; move it down to STOP
9	9	REM ECHO The same command received , START or STOP, is sent to the device connected
10	10	S/S STAB S/S IMPULS The logic outputs are stable in the OFF position; pulsed in the ON position (~ 1 sec), if the option is provided

Line - Line Digital Inputs Pin-out

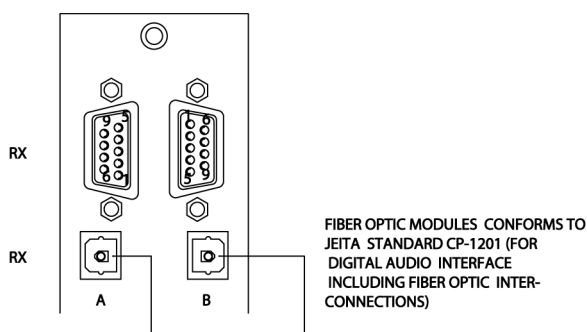

INPUT DIGITAL/DIGITAL MODULE CONNECTIONS

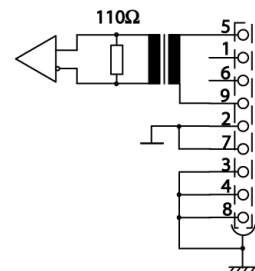

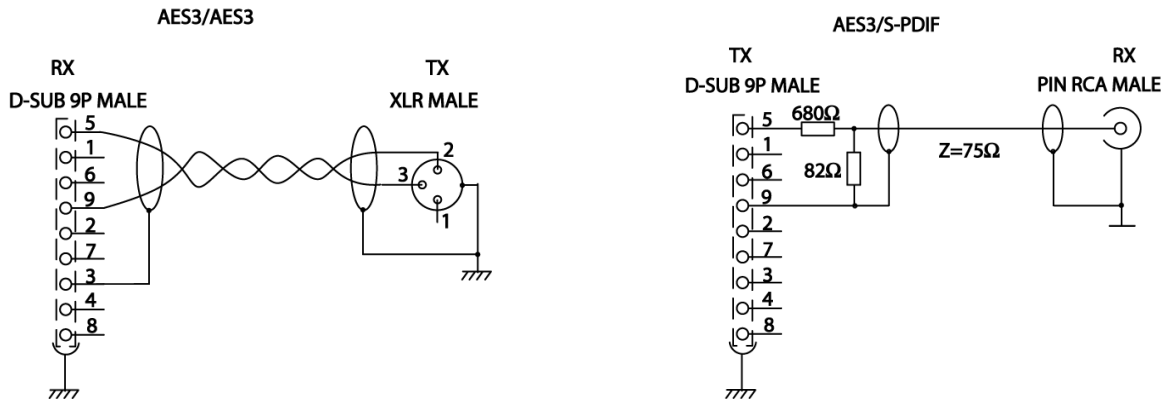

DIGITAL INPUT DIP SWITCH FUNCTION NOTES

A	B	OFF ON
1	1	Reset Timer When the channel switches over to START mode, a pulse is emitted (through the VU-Meter connector) to restart the external timer
2	2	WR OPTO Select the connection type Write or Opto
3	3	TB-Studio/Room When the channel is in STOP mode, press the TB button to send the s signal to the output of the Control Room, Headphones and Speaker and the Control Studio Mute is disabled
4	4	Speaker Mute When the channel changes over to START mode, the Speaker output will be disabled
5	5	CR Mute When the channel changes over to START, the Control Room output will be disabled
6	6	ST Mute When the channel changes over to START mode, the Control Studio output is disabled
7	7	ON AIR Tally When the channel changes over to START mode, with the PGM activated, the ON AIR control contact closes
8	8	SLIDER S/S Move the slider up to START; move it down to STOP
9	9	REM ECHO The same command received , START or STOP, is sent to the device connected
10	10	S/S STAB S/S IMPULS The logic outputs are stable in the OFF position;

Telephone Pin-out / Setup

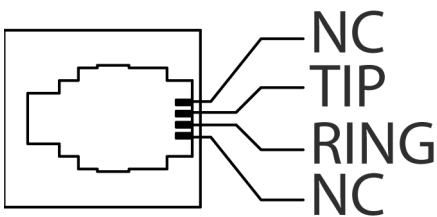

TELEPHONE DIP SWITCH FUNCTION NOTE

A	OFF ON
1	Reset Timer When the channel changes over to START mode, a pulse is emitted (through the VU-meter connector) to restart the external timer
2	Speaker Mute When the channel changes over to START mode, the Speaker output is disabled
3	CR Mute When the channel changes over to START mode, the Control Room output will be disabled
4	ST Mute When the channel changes over to START mode, the Control Studio output will be disabled

- 5 ON AIR Tally When the channel changes over to START mode with the PGM activated, the ON AIR control contact will close
- 6 SLIDER S/S Move the slider down to START , move the slider up to STOP
- 7 REM ECHO Sends the same command received (START and STOP) to the device connected, if the option has been provided
- 8 S/S STAB The logic outputs are stable in the OFF position; pulsed in ON position (~ 1 sec.)
S/S IMPULS
- 9 0 dB The gain options are being transmitted over the telephone network + 3 dB
- 10 START/STOP OUT-Call/Hook IN-Hook/OnAir Select the associated function I/O:

ON IN/OUT START as for M/L and L/L
IN/OUT STOP as for M/L and L/L
OFF IN HOOK (TOGGLE) line hook-up
PGM ON + START (ONE TIME)
HOOK

CALL See Pin-out GPI – GPO If the option is provided

GPI - GPO Pin-out

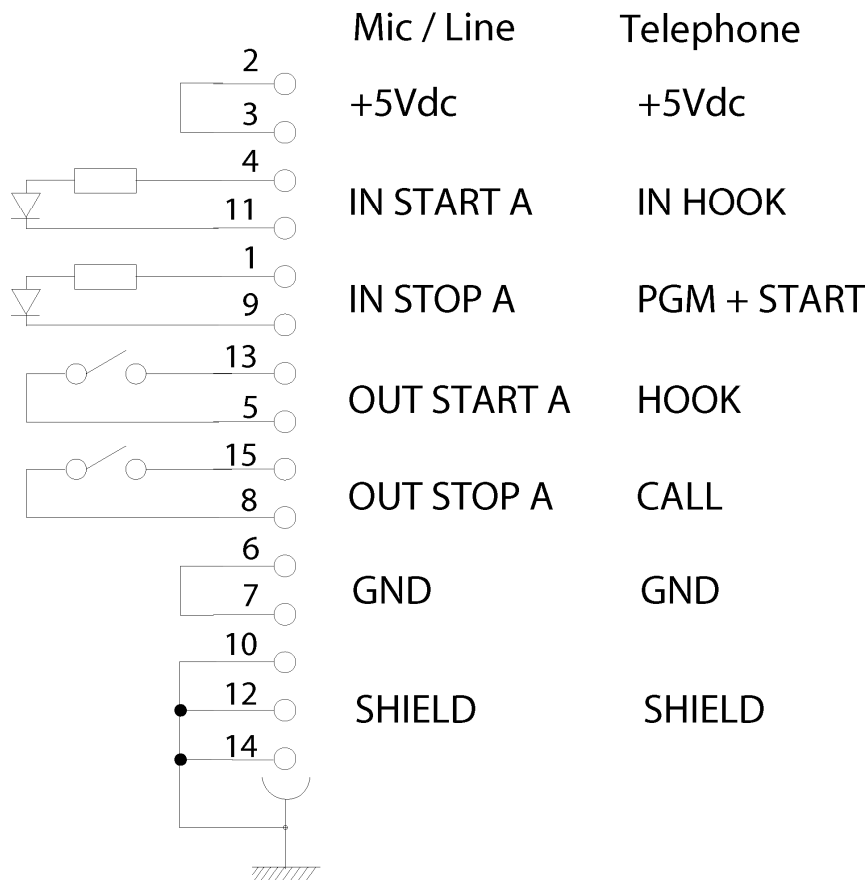
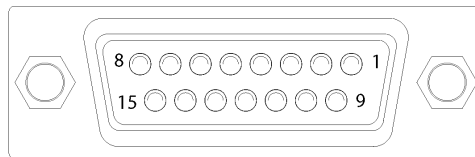

Master Setup

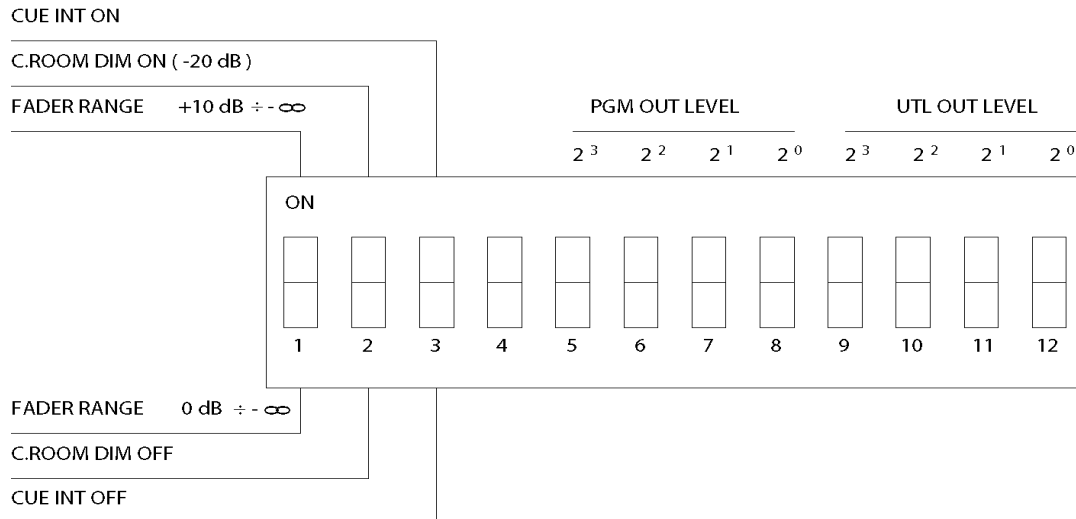

GAIN SET TABLE

GAIN dB	2 ³	2 ²	2 ¹	2 ⁰
+13	ON	ON	ON	ON
+12	ON	ON	ON	OFF
+11	ON	ON	OFF	ON
+10	ON	ON	OFF	OFF
+9	ON	OFF	ON	ON
+8	ON	OFF	ON	OFF
+7	ON	OFF	OFF	ON
+6	ON	OFF	OFF	OFF
+5	OFF	ON	ON	ON
+4	OFF	ON	ON	OFF
+3	OFF	ON	OFF	ON
+2	OFF	ON	OFF	OFF
+1	OFF	OFF	ON	ON
-0	OFF	OFF	ON	OFF
-1	OFF	OFF	OFF	ON
-2	OFF	OFF	OFF	OFF

Master Pin-out

CONTROL STUDIO OUT

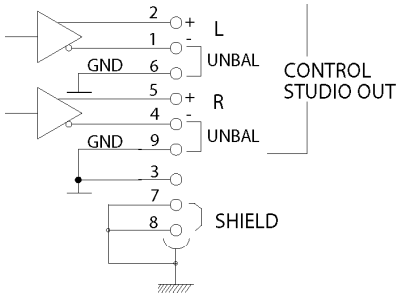
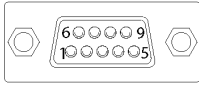

UTL OUT

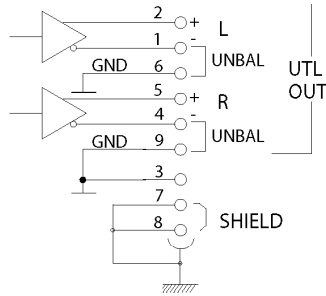
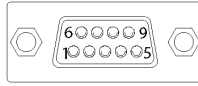

EXT 2 IN

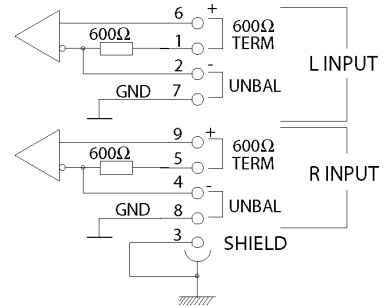
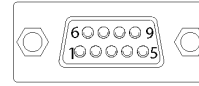

MUTAB.CNTRL STUDIO

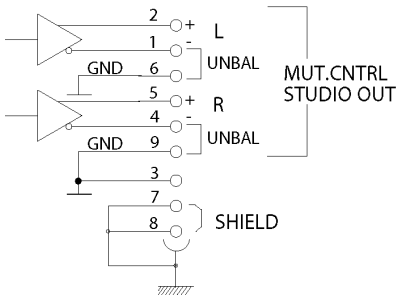
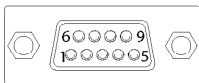

PGM OUT

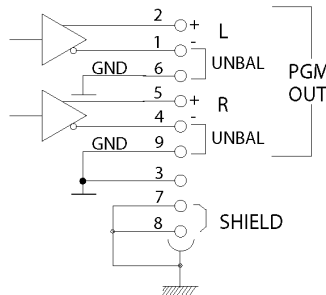
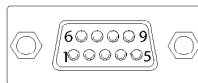

EXT 1 IN

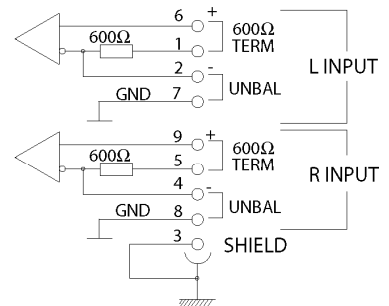
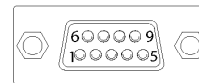

CONTROL ROOM

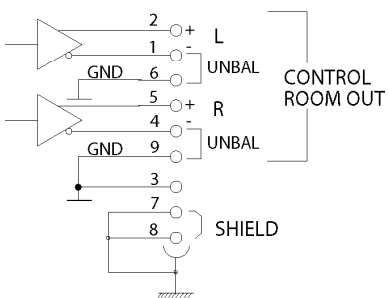

VU METER

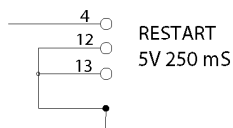
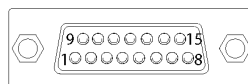

ON AIR

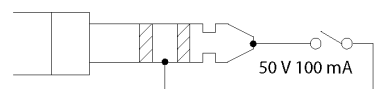

Master Output connection (PGM - UTL - C.STUDIO - C.ROOM)

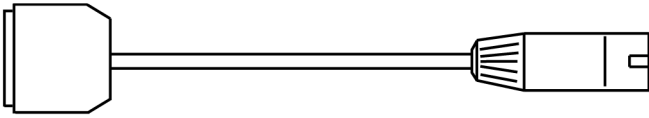

Out Balanced XLR

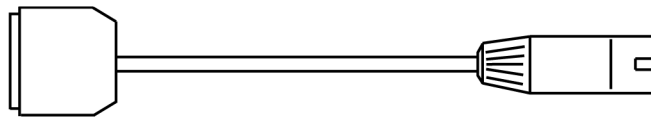
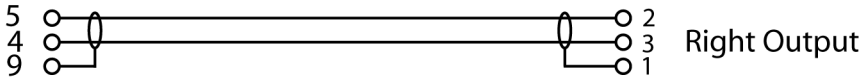
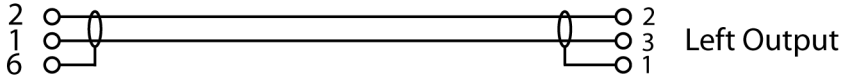

Out Unbalanced XLR

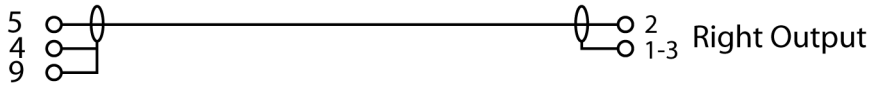
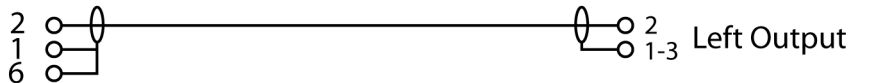

Out Unbalanced Pin

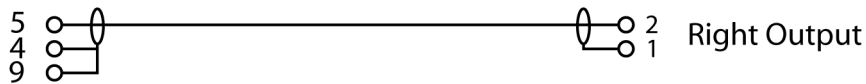
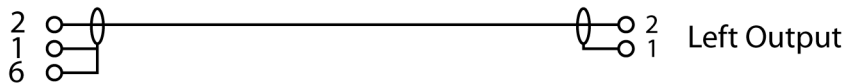

Master Input connection (EXT 1 - EXT 2)

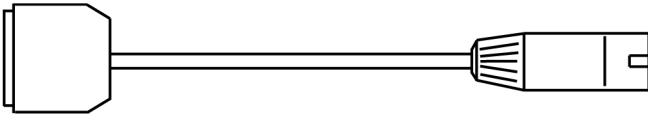

600 ohm Balanced XLR

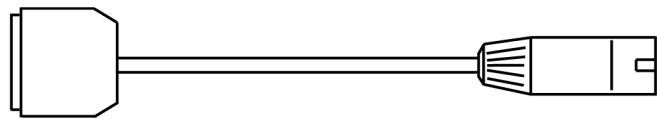
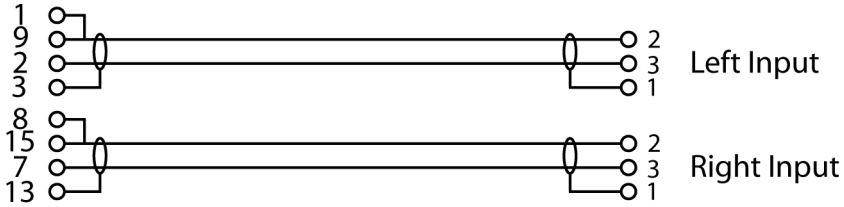

Balanced XLR

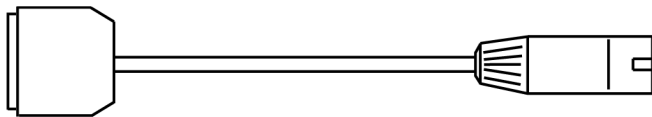
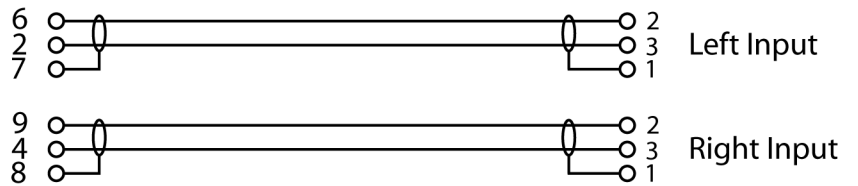

Unbalanced XLR

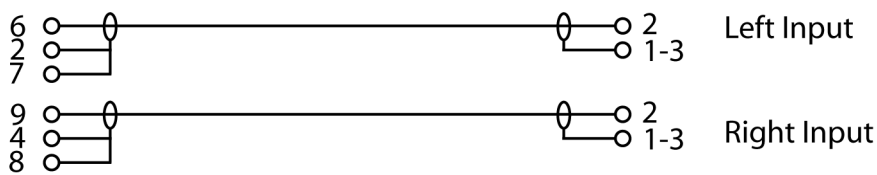

Unbalanced Pin

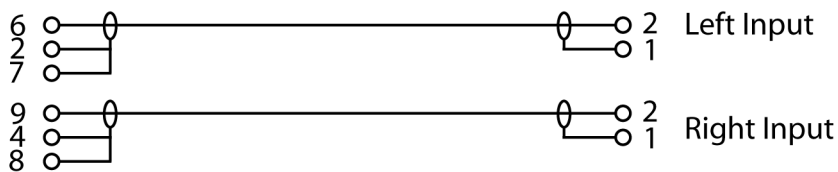

Master Digital Pin-out

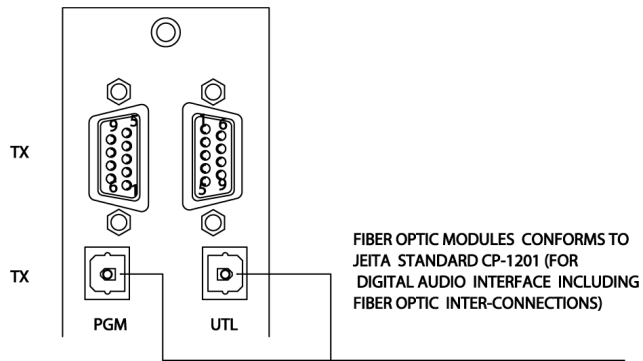

MASTER DIGITAL OUTPUT MODULE CONNECTIONS

internal side Synapse

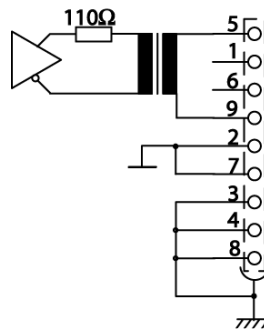

external side Synapse

external side Synapse

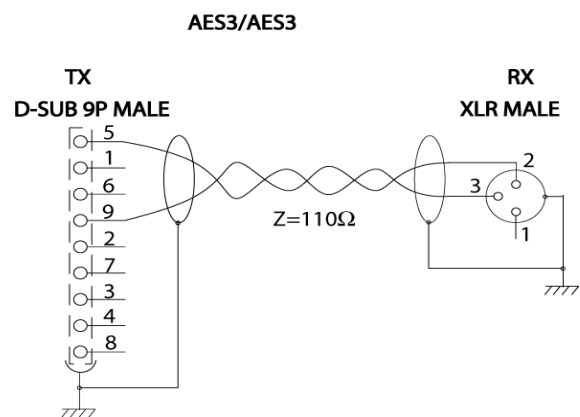
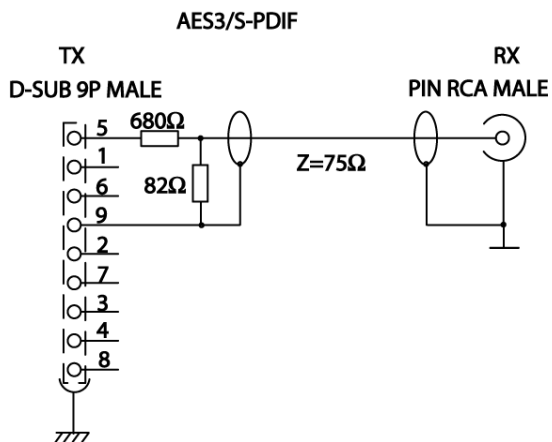

Technical Specification

MICROPHONE INPUT

Input configuration:	transformer balanced
Source Impedance:	200 Ω
Sensitivity Level Range	Adjustable from -70 ÷ -40 dBu (trimmer adj.)
Input Level Range:	± 12 dBu (Digital adj. step 0,5 dB)
Maximum Input Level:	-30 dBu
Phantom Supply:	48 Vdc selectable, with 3k3 c.c. protection
100 mm Fader control:	VCA Digital controlled
Tone Control (Optional)	3 Bands Low / Mid / High ± 14 dBu

MICROPHONE INSERT - DJ Controls

Insert Output configuration:	Unbalanced
Insert Output Impedance:	100 Ω
Insert Output Level:	0 dBu
Insert Input configuration:	Unbalanced
Insert Source Impedance:	10 K Ω
Insert Input Level:	0 dBu
External DJ Slider control - DJ Talk Back - In Connector:	Start / Stop / Cough control - Out Start / Stop control DSUB 15 pole female

LINE INPUT

Input configuration:	Electronically balanced
Input Impedance:	>10 K Ω (600 Ω wired selectable)
Input Level:	± 12 dBu (Digital adj. step 0,5 dB)
Headroom:	+ 18 dBu
100 mm Fader control:	VCA Digital controlled
Connector:	In Start / Stop control - Out Start / Stop control DSUB 15 pole female
Tone Control (Optional)	3 Bands Low / Mid / High ± 14 dBu

DIGITAL INPUT

Input configuration:	AES/EBU, IEC958, S/PDIF & EIAJ CP340/1201 Professional and consumer
Sample Rate	Automatic 32 44.1 48 96 KHz converter
100 mm Fader control:	VCA Digital controlled
Tone Control (Optional)	3 Bands Low / Mid / High ± 14 dBu
Connector:	DSUB 15 pole female - Optical

TELEPHONE HYBRID MODULE

Input configuration:	Opto-coupled
Input Impedance:	600 Ω Balanced
Line Compensation:	Automatically (max 5 Km)
Echo canceller:	Digital (optional)
Tx Level:	0 OR + 3 dBu
Rx Level:	± 12 dBu (Digital adj. step 0,5 dB)
Frequency response:	300 Hz ÷ 3400 Hz (-2 dB) without Echocanceller 300 Hz ÷ 3400 Hz (-1.5 dB) with Echocanceller
Distorsion:	< 1.5 %
Noise:	-60 dB

Cross-talk: Digitally cancelled
Tone Control: Tone Control (Optional) 3 Bands Low / Mid / High \pm 14 dBu
In Start / Stop control - Out Start / Stop control - In Lock / Meeting control - Out Call / Lock control

EXTERNAL INPUT

Input configuration: Electronically balanced
Input Impedance: $>10\text{ K}\Omega$ ($600\ \Omega$ wired selectable)
Input Level: $\pm 12\text{ dBu}$ (Digital adj. step 0,5 dB)
Headroom: + 18 dBu
Connector: DSUB 9 pole female

ANALOG OUTPUTS

Output configuration: Electronically balanced
Output Impedance: $100\ \Omega$
PGM Output Level Range: $-2 \div +13\text{ dBu}$ (1 dB step dip switch selectable)
Connector: DSUB 9 pole female
UTL Output Level Range: $-2 \div +13\text{ dBu}$ (1 dB step dip switch selectable)
Connector: DSUB 9 pole female
C Studio Mut. Output Level Range: $-\infty \div +12\text{ dBu}$
Connector: DSUB 9 pole female
C Room Mut. Output Level Range: $-\infty \div +12\text{ dBu}$
Connector: DSUB 9 pole female
C Studio no Mut. Output Level Range: 0 dBu
Connector: DSUB 9 pole female

DIGITAL OUTPUTS

Output configuration: AES/EBU, IEC958,S/PDIF & EIAJ CP340/1201 Professional and consumer
Sample rate: Selectable 32 44.1 48 96 KHz
Connector: DSUB 9 pole female - Optical

HEADPHONES (C.Room no Muted):

Configuration Type: Stereo unbalanced
Output Impedance: $50\ \Omega$
Connector: JACK 6,3 mm
Output Level Range: $-\infty \div +6\text{ dBu}$

LOGIC INPUT

Configuration: Opto-coupled (with internally 330 ohm protection)
Max Voltage input: 5 Vdc (for 10 mA input)
Max Reverse Voltage: 5 Vdc
Connector: DSUB 15 pole female

LOGIC OUTPUT

Configuration: Optic solid state relay
Max Voltage: 50 Vdc/ac
Max Current: 100 mA
Connector: DSUB 15 pole female

GENERAL SPECIFICATIONS

FREQUENCY RESPONSE

Microphone Input to program output	20 Hz ÷ 20 KHz ±1 dB (50 Hz ÷ 20 KHz ± 0.3 dB)
Line Input to program output	30 Hz ÷ 20 KHz ±0.3 dB (20 Hz ÷ 20 KHz ± 1 dB)

NOISE

Micro Amplifier	-130 dBu RMS equivalent input noise, 200 Ω source, 20 KHz bandwidth
Line Amplifier	-120 dBu RMS equivalent input noise, 600 Ω source, 20 KHz bandwidth
Output Noise:	better than -84 dB (A-Weighted 10 Hz / 23 KHz), -72 dB (CCIR Wght) <i>with one microphone channel ON, fader at 0 dB, input sensitivity at -40 dB, 200 Ω source</i>
Output Noise:	better than -86 dB (A-Weighted 10 Hz / 23 KHz), -75 dB (CCIR Wght) <i>with one line channel ON, fader at 0 dB, input sensitivity at 0 dB</i>
Output Noise:	better than -89 dB (A-Weighted 10 Hz / 23 KHz), -78 dB (CCIR Wght) with all input channel OFF

DISTORTION T.H.D.

Microphone Input to program output:	Less than 0.018 %
Line Input to program output:	Less than 0.007 %

ASSIGN ISOLATION

1 KHz	better than -86 dB
20 KHz	better than -85 dB

CROSSTALK L/R

1 KHz	better than -78 dB
20 KHz	better than -66 dB

CROSSTALK PGM/Other OUT

20 Hz ÷ 20 KHz	better than -76 dB
----------------	--------------------

CMRR (Line Input)

60 Hz	-56 dB
1 KHz	-56 dB
20 KHz	-56 dB

GENERAL DATA

Power Supply	100 ÷ 240 VAC 50 – 60 Hz
Power Requirement	25 VA
Operating Temperature	0 ÷ 50 °C